

Rear Wheel Well Protective Plate

Installation Instructions

MAVERICK

What's Included

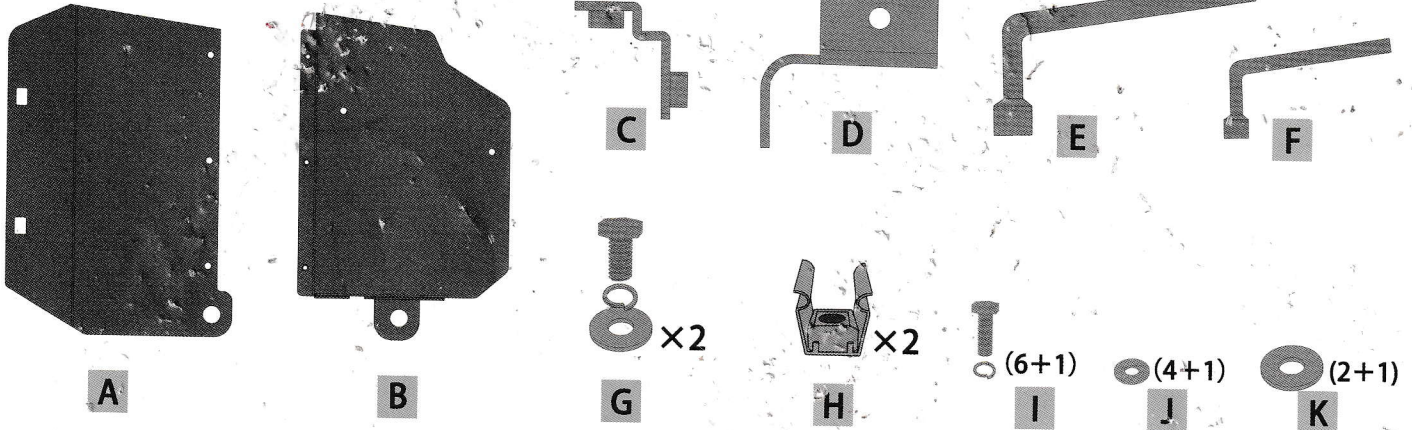

Note: Before installation, ensure that the vehicle is parked and the exhaust pipe has cooled down to prevent burns.

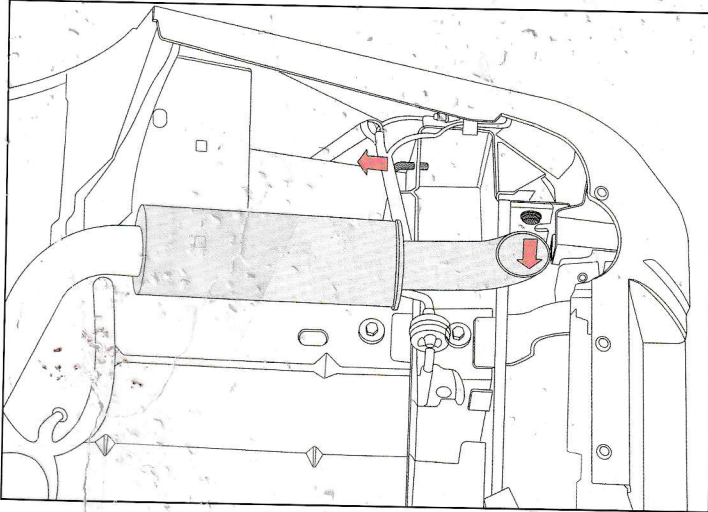

1. Remove the wiring harness and make space for the holes. Use socket wrench to remove the original screws and set them aside for later use.

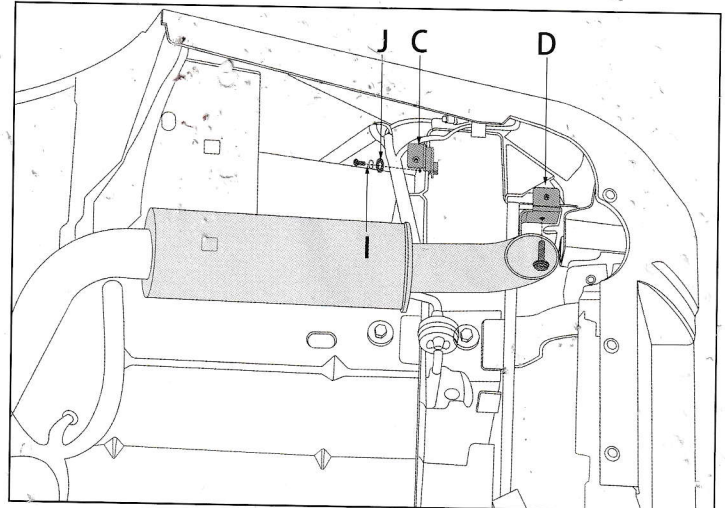

2. Use a socket wrench to attach the accessory (D) in the original screw locations, and secure the accessory (C) with screws and washers.

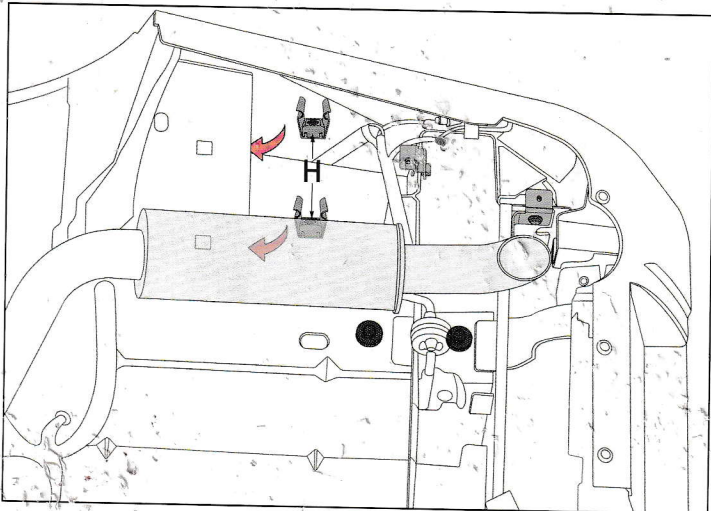

3. Insert the accessory (H) into the base plate according to the direction indicated by the arrows, aligning it with the appropriate holes.

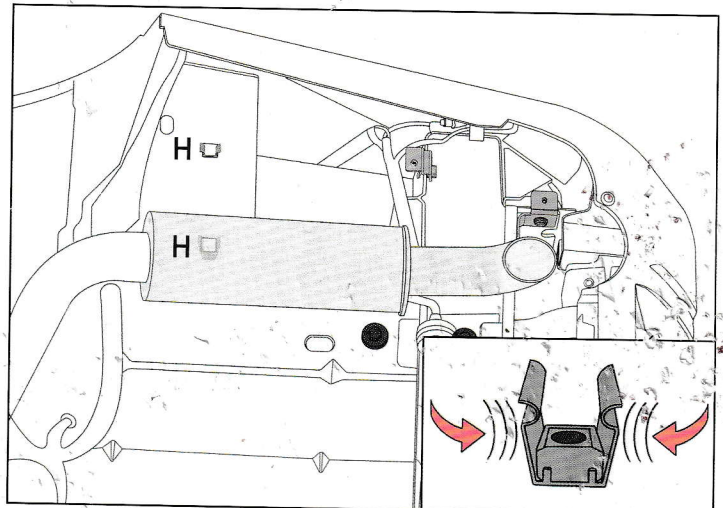

4. Compress both sides of accessory (H) to help it fit smoothly into the holes.

Note: If the protective cover cannot pass through, you can remove one end of the highlighted section from step 6.

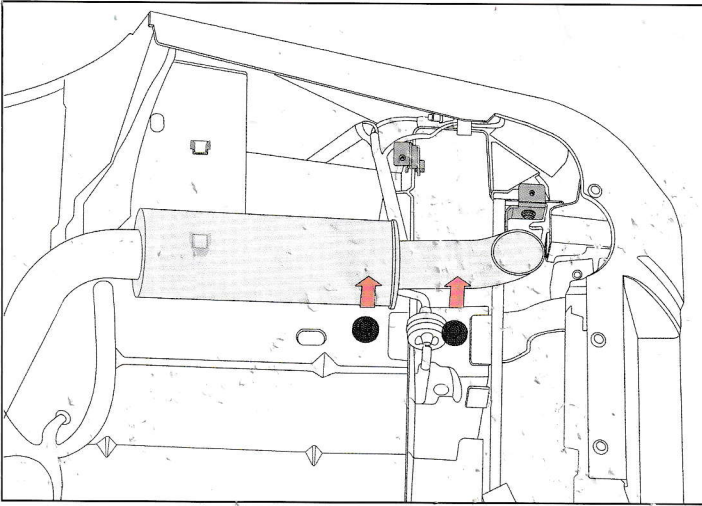

5. Use socket wrench to remove the original screws and set them aside for later use.

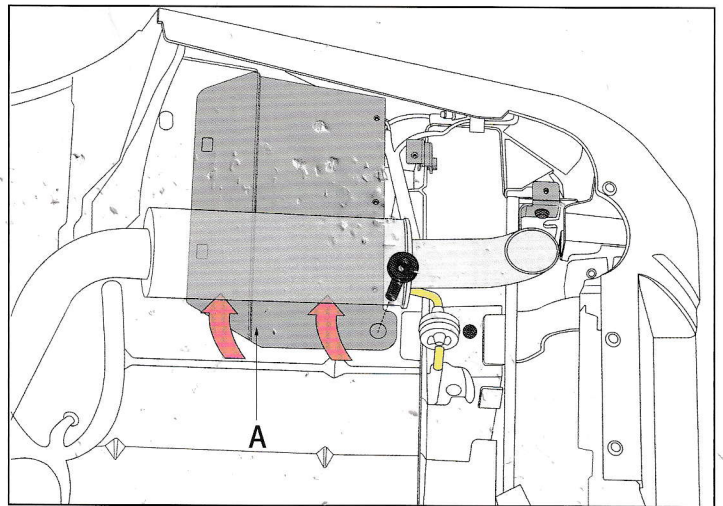

6. Pass the protective plate (A) through the gap between the exhaust pipe and the chassis according to the direction indicated by the arrows, and secure it with the original screws.

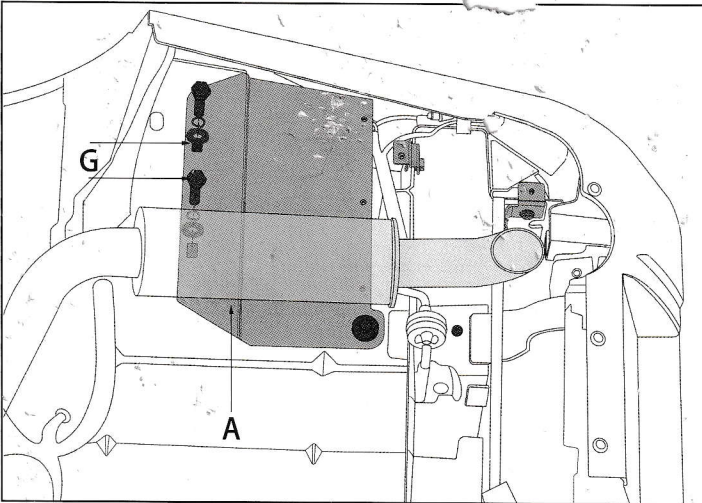

7. Use socket wrench to tighten screws (G) to secure the protective plate (A).

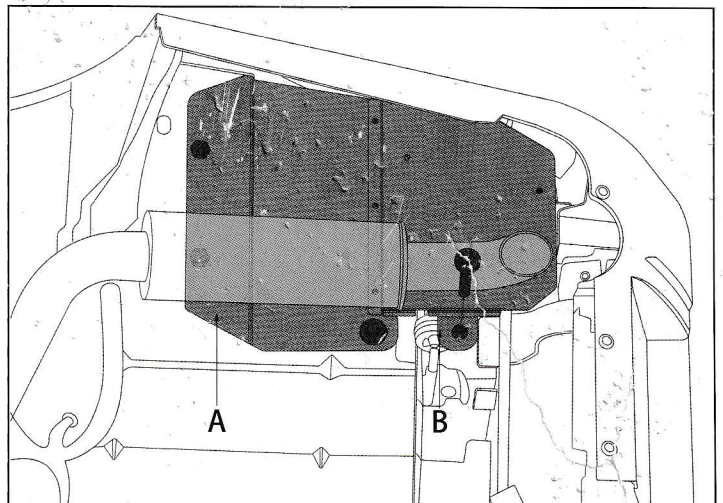

8. Install protective plate (B) in the same manner and secure it with the original screws.

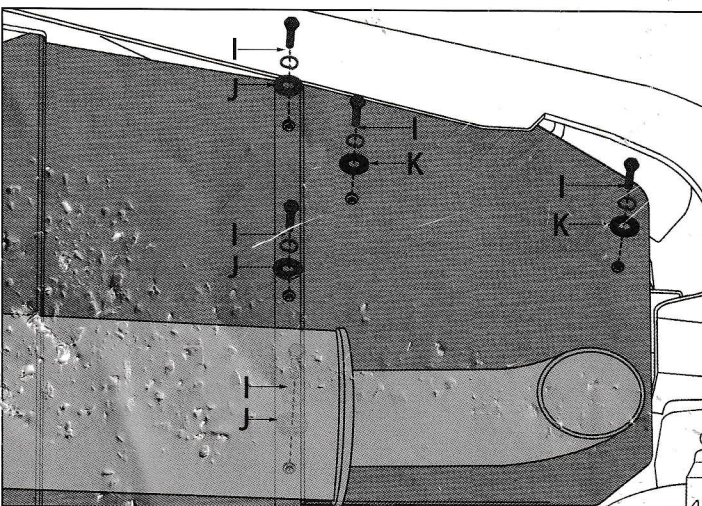

9. Use screws (×5) to fix both protective plates in their respective holes, and tighten all screws after they are inserted.

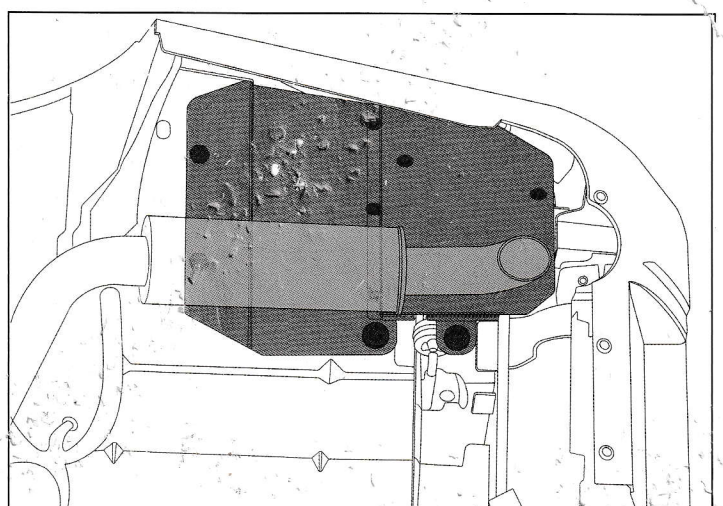

10. Confirm that the installation is complete.