

2023 Maverick Lariat Fog Light, LED Hood and Side Marker Lighting

DD supplied switch not used – substituted latched lighted pushbutton switch

LED (+) for each switch is tied to the 12V return for that switch so that the LED only lights when power flows through the switch to the load when switch is depressed

LED (-) ground for each switch has an inline 47K ohm resistor before being soldered together and grounded at the brake booster

Top switch returns provide 12V back to the loads (For fog lights the relay via white wire)

Bottom switch currently not in use - 12V power and return leads in engine compartment for future additional option

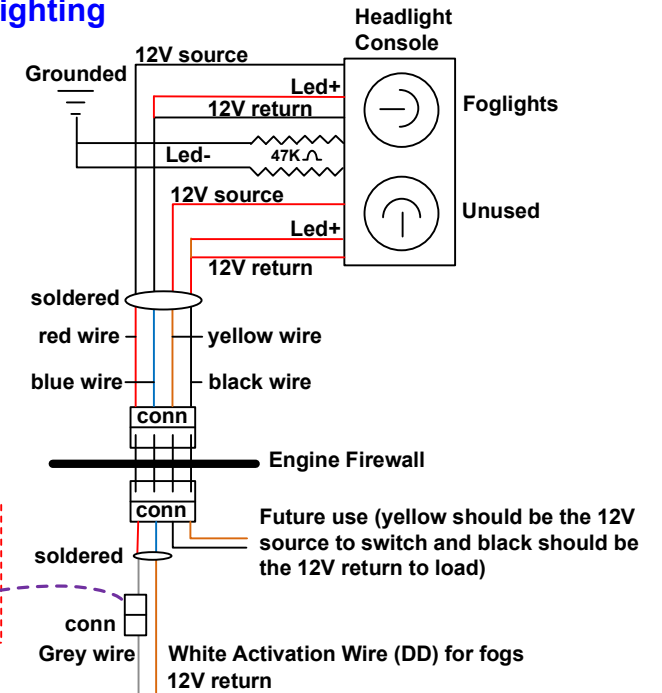
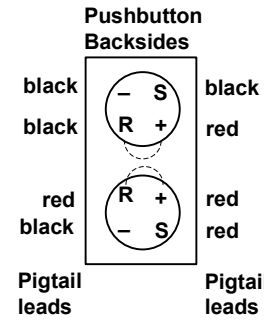

Driver Headlight Connector

Optional (DD suggested) cabling to low beam headlight via drivers side blue wire with green stripe or possibly blue with brown. Can also use deactivation wire to shut down fogs with high beams on.

See Page 2 for Modified Front Grill Turn Signals

