

501-12 Instrument Panel and Console
Removal and Installation

2025 Maverick

Procedure revision date: 10/1/2024

Instrument Panel

Special Tool(s) / General Equipment

Interior Trim Remover

Removal

NOTE: Removal steps in this procedure may contain installation details.

1. Evacuate the refrigerant.

Refer to: [Air Conditioning \(A/C\) System Recovery, Evacuation and Charging - Full Hybrid Electric Vehicle \(FHEV\)](#) (412-00 Climate Control System - General Information, General Procedures).

Refer to: [Air Conditioning \(A/C\) System Recovery, Evacuation and Charging - 2.0L EcoBoost \(177kW/240PS\) – MI4](#) (412-00 Climate Control System - General Information, General Procedures).

2. **NOTICE: Only use the specified material to lubricate the seals.**

NOTE: Make sure to cover any open ports to prevent debris from entering the system.

Remove the nut and remove the HVAC flange.

- On installation, install and lubricate new O-ring seals.

Refer to: [Refrigerant Oil Adding - Full Hybrid Electric Vehicle \(FHEV\)](#) (412-00 Climate Control System - General Information, General Procedures).

Refer to: [Refrigerant Oil Adding](#) (412-00 Climate Control System - General Information, General Procedures).

Torque: 159 lb.in (18 Nm)

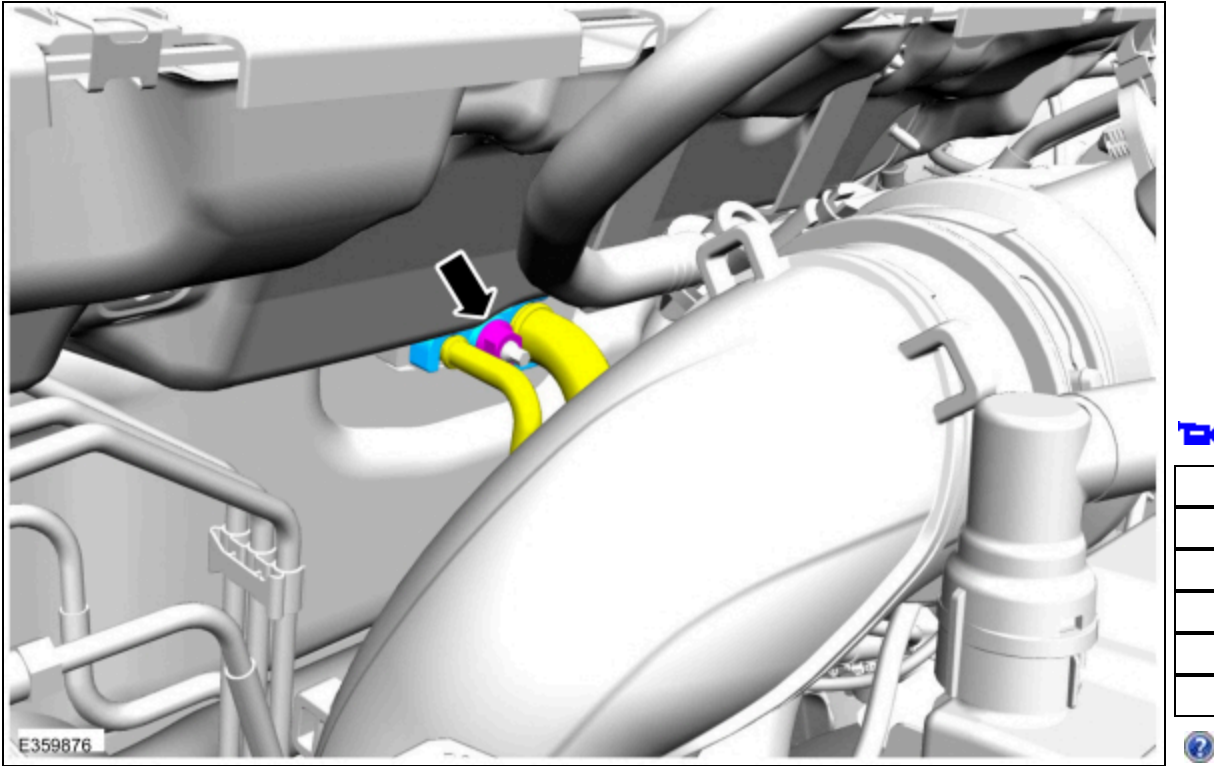

3.
 1. Pinch hoses.
 2. Remove clamps and position aside the hoses.

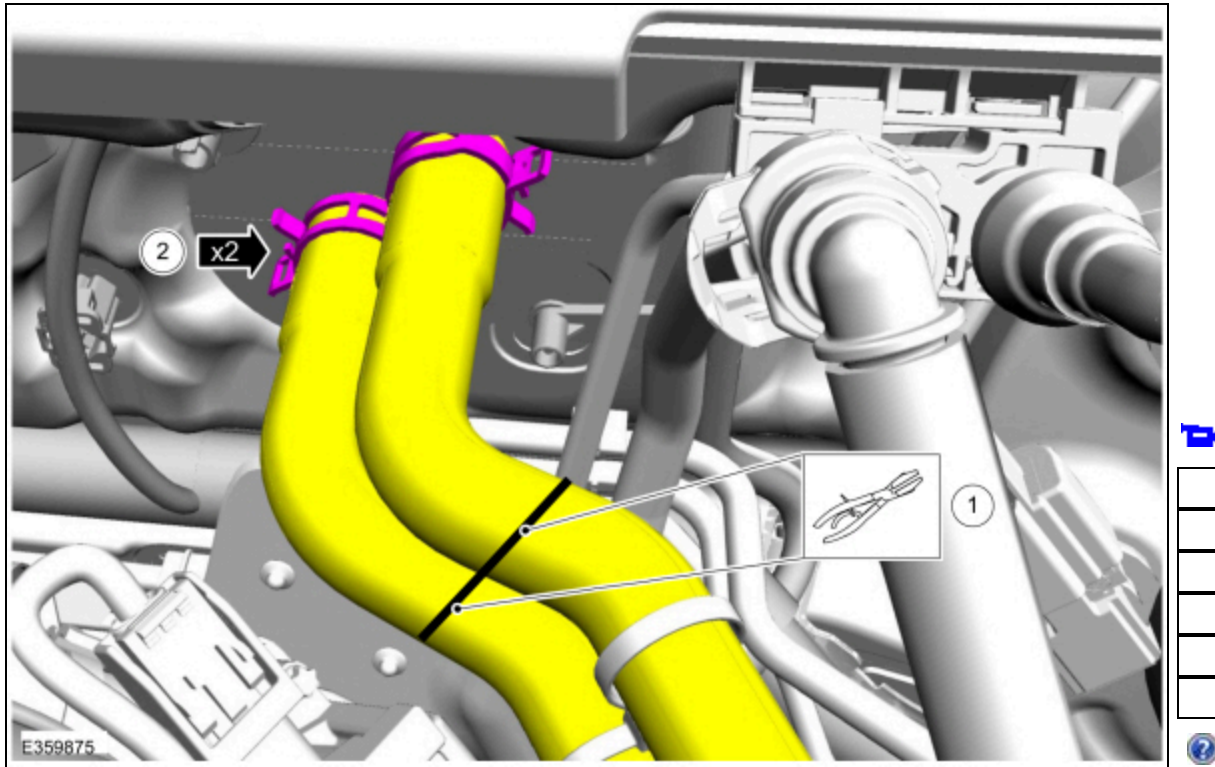

4. Remove the cowl panel grille.
Refer to: [Cowl Panel Grille](#) (501-02 Front End Body Panels, Removal and Installation).
5. Remove the bolts.
Torque: 18 lb.ft (25 Nm)

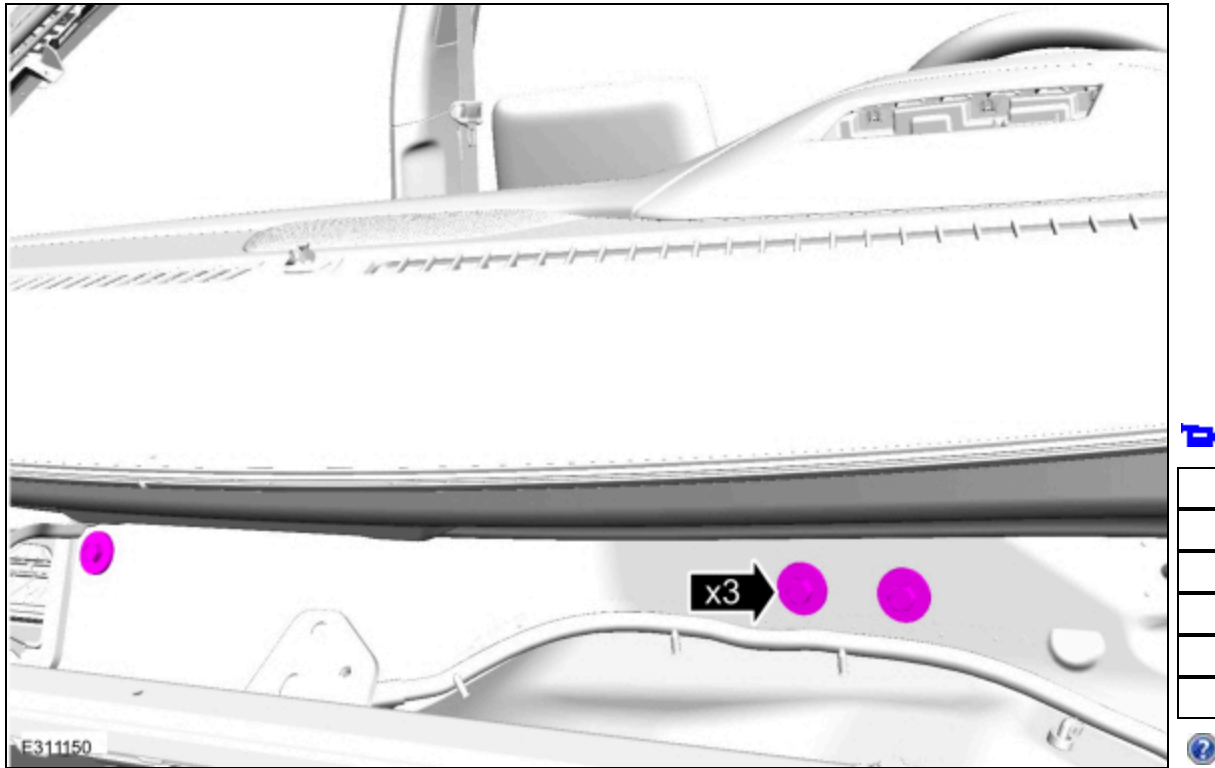

6. Remove the driver side front door.
Refer to: [Front Door](#) (501-03 Body Closures, Removal and Installation).
7. Remove the front seats.
Refer to: [Front Seat](#) (501-10A Front Seats, Removal and Installation).
8. Remove the floor console.
Refer to: [Floor Console](#) (501-12 Instrument Panel and Console, Removal and Installation).
9. Remove the A-pillar trim panels.
Refer to: [A-Pillar Trim Panel](#) (501-05 Interior Trim and Ornamentation, Removal and Installation).
10. **NOTE:** *Right hand A-pillar.*
Disconnect the electrical connector.

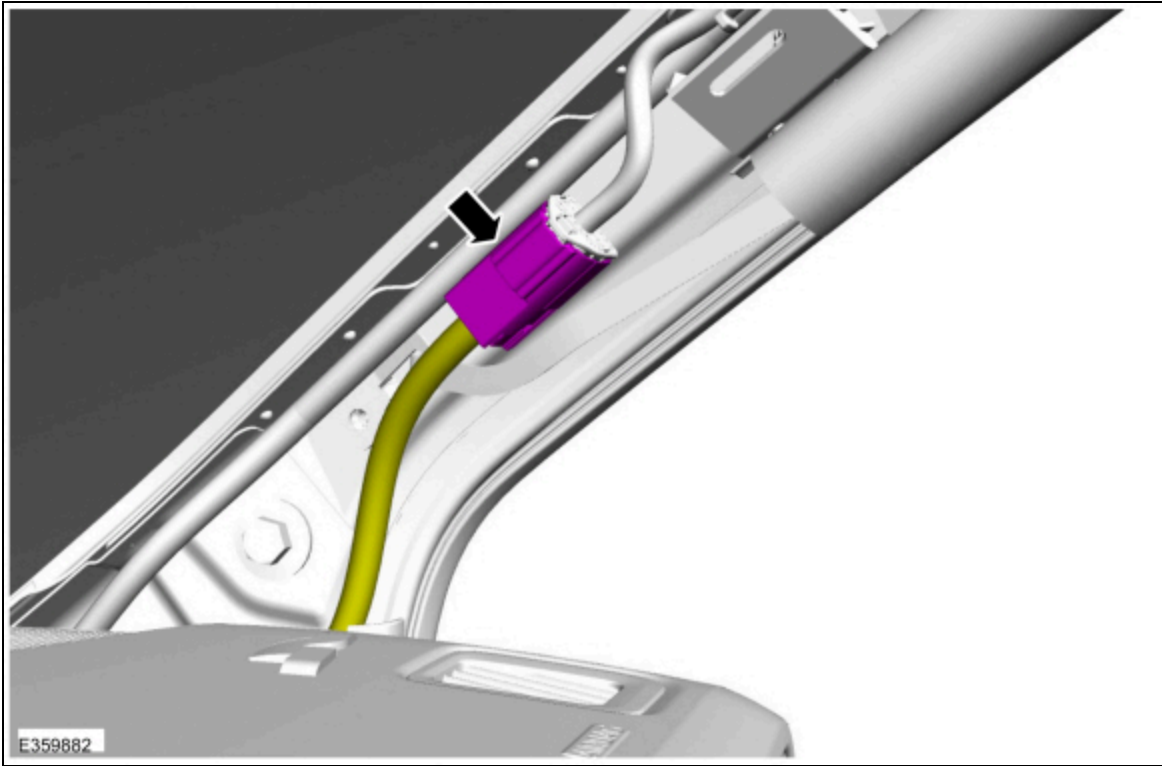

- 11. Release the retainers and remove the RH instrument panel speaker grille.
Use the General Equipment: Interior Trim Remover

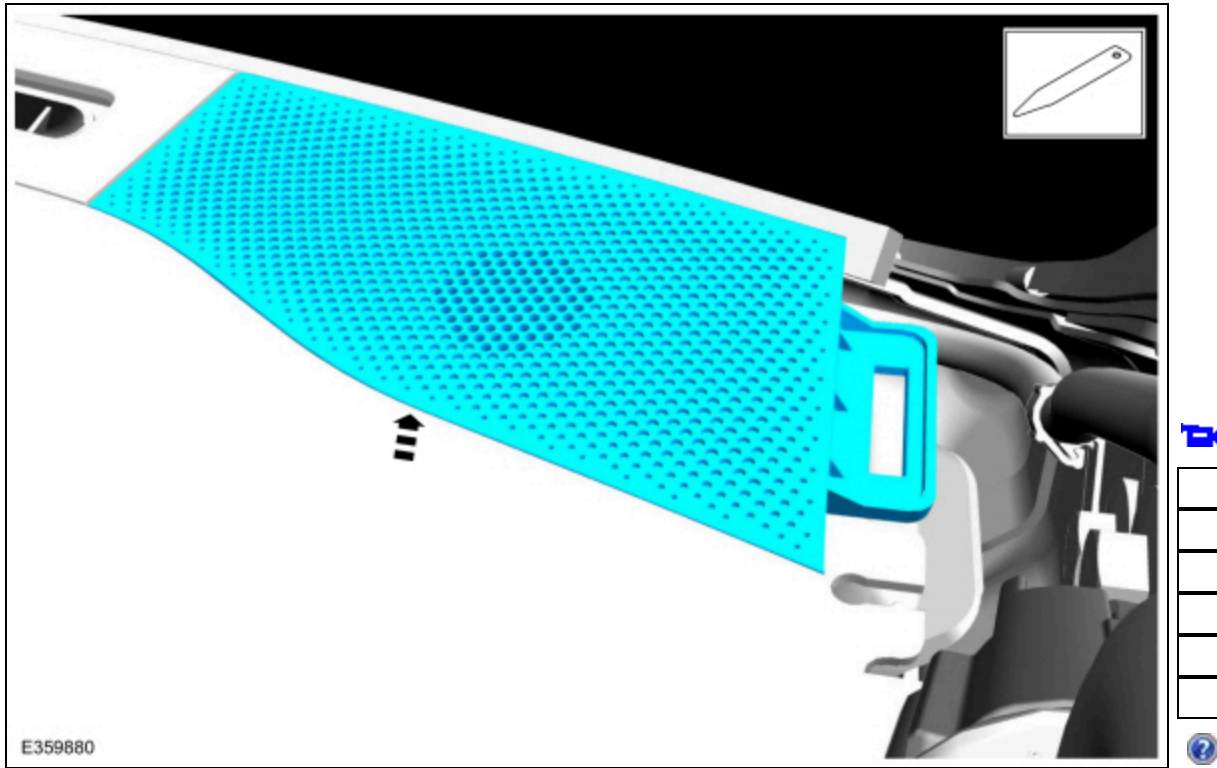

- 12. Remove the bolt.
Torque: 22 lb.in (2.5 Nm)

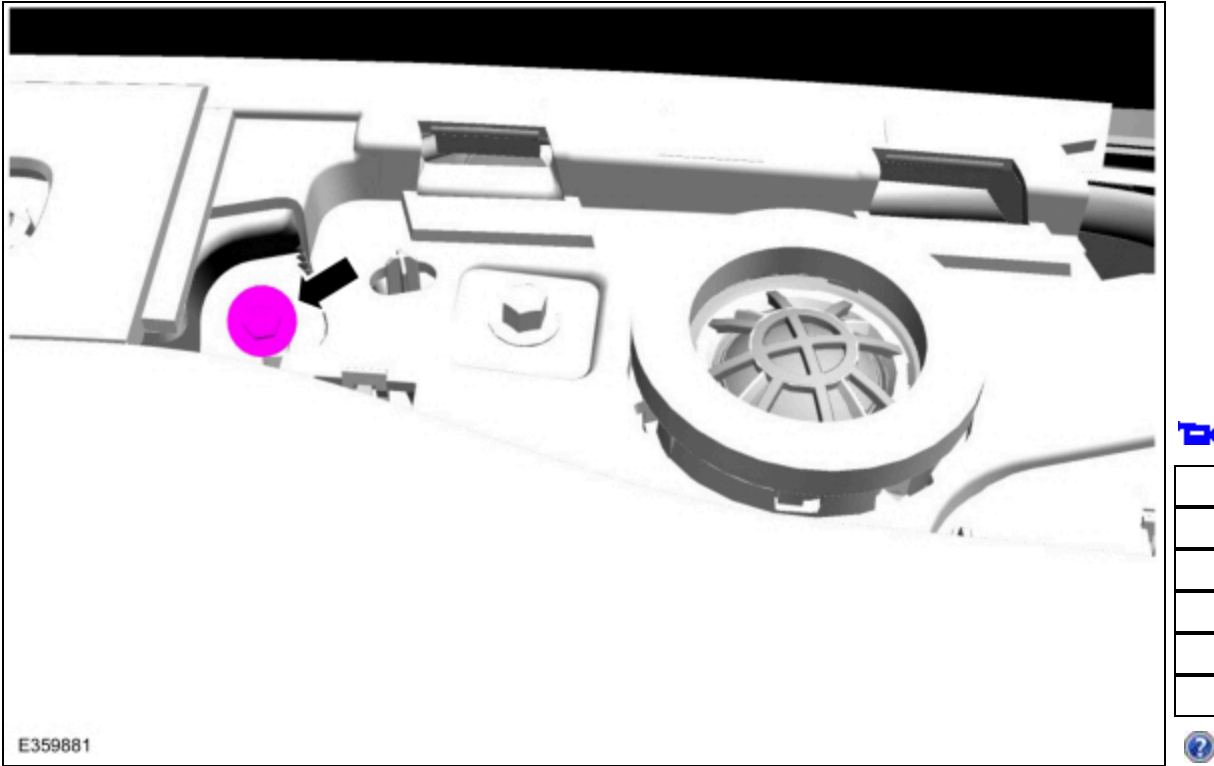

13. **NOTE:** *Left hand A-pillar.*

Disconnect the electrical connector.

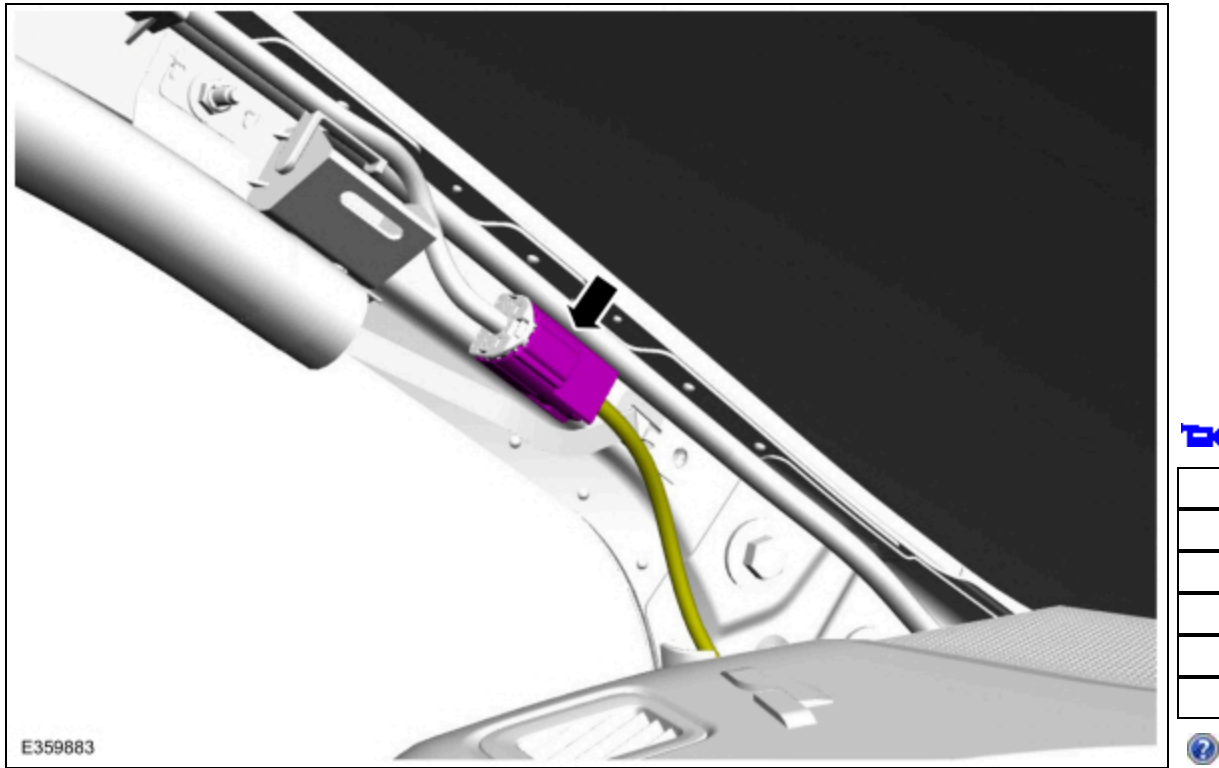

14. Position aside the weather strip, release the retainers and remove the RH instrument panel end cap. Use the General Equipment: Interior Trim Remover

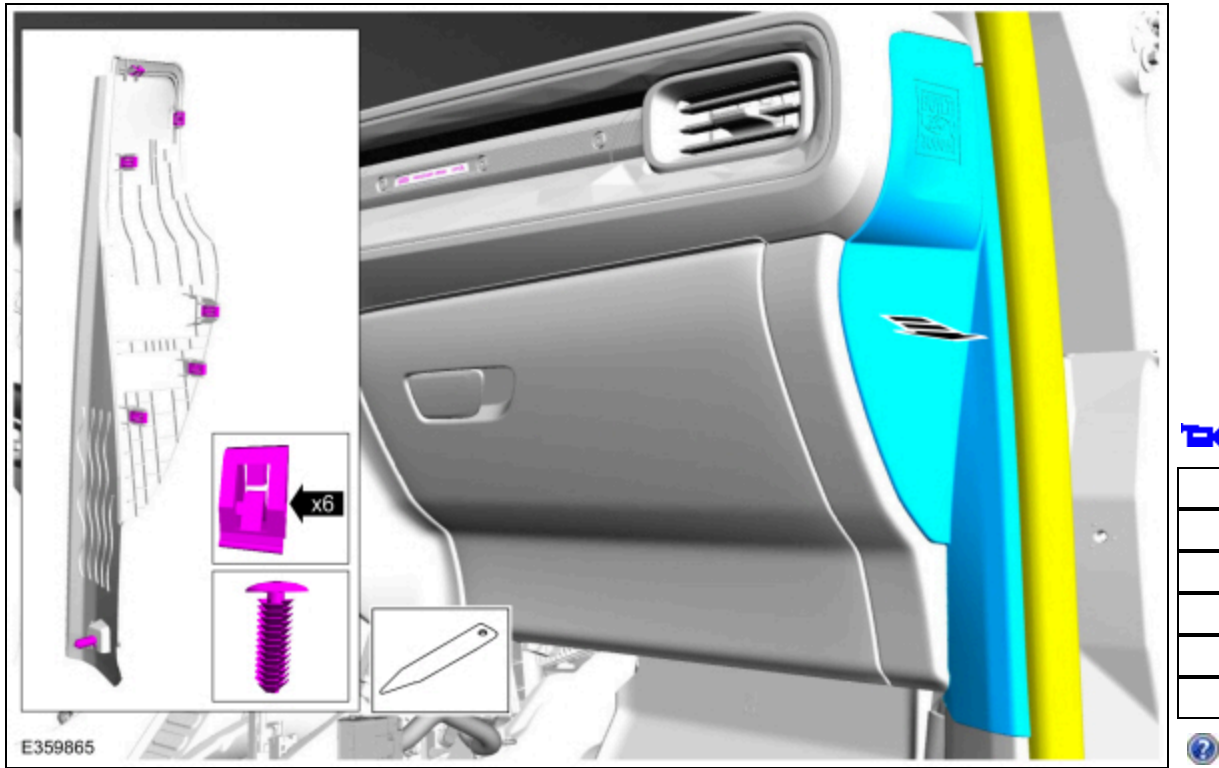

- 15. Release the retainers and remove the RH lower cowl trim panel.
Use the General Equipment: Interior Trim Remover

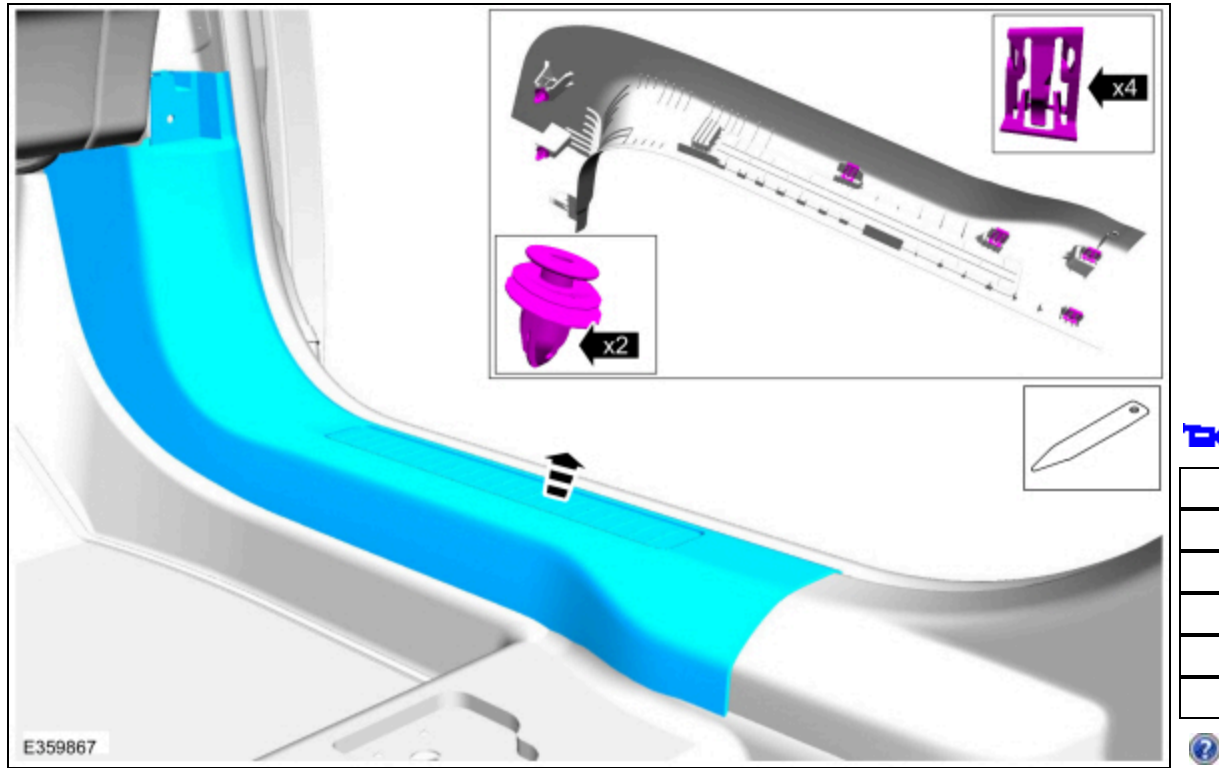

16. Position aside the weather strip, release the retainers and remove the LH instrument panel end cap. Use the General Equipment: Interior Trim Remover

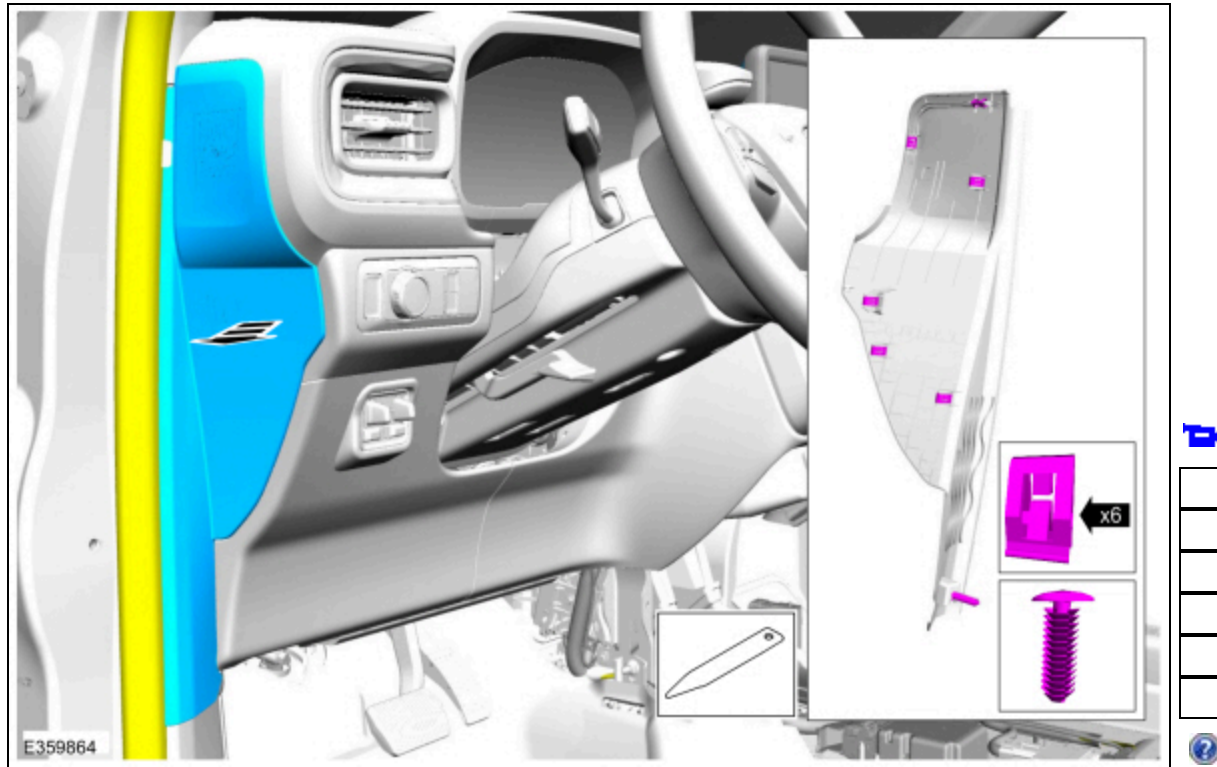

17.

Remove the hood latch release handle.

1. Rotate the hood latch release handle.
2. **NOTE:** Do not remove the retaining clip from the hood latch release handle.

Release the retaining clip.
3. Remove the hood latch release handle.

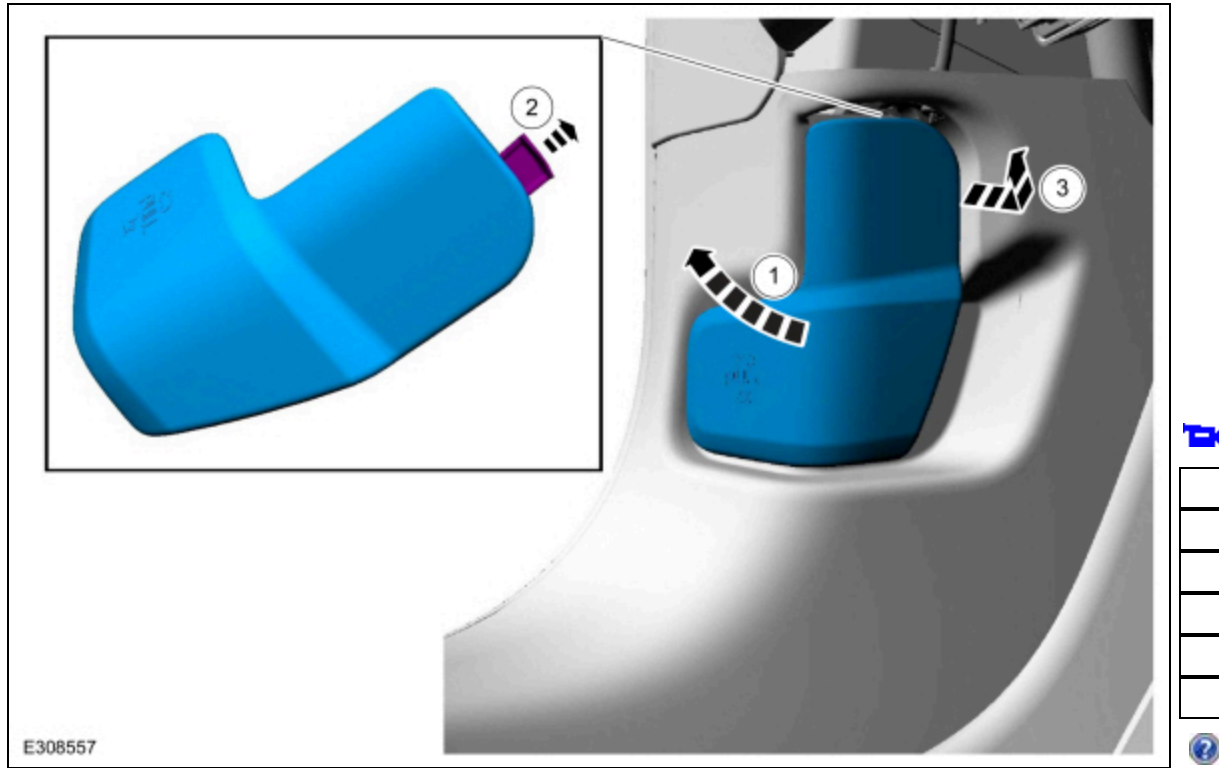

18. Release the retainers and remove the LH lower cowl trim panel.
Use the General Equipment: Interior Trim Remover

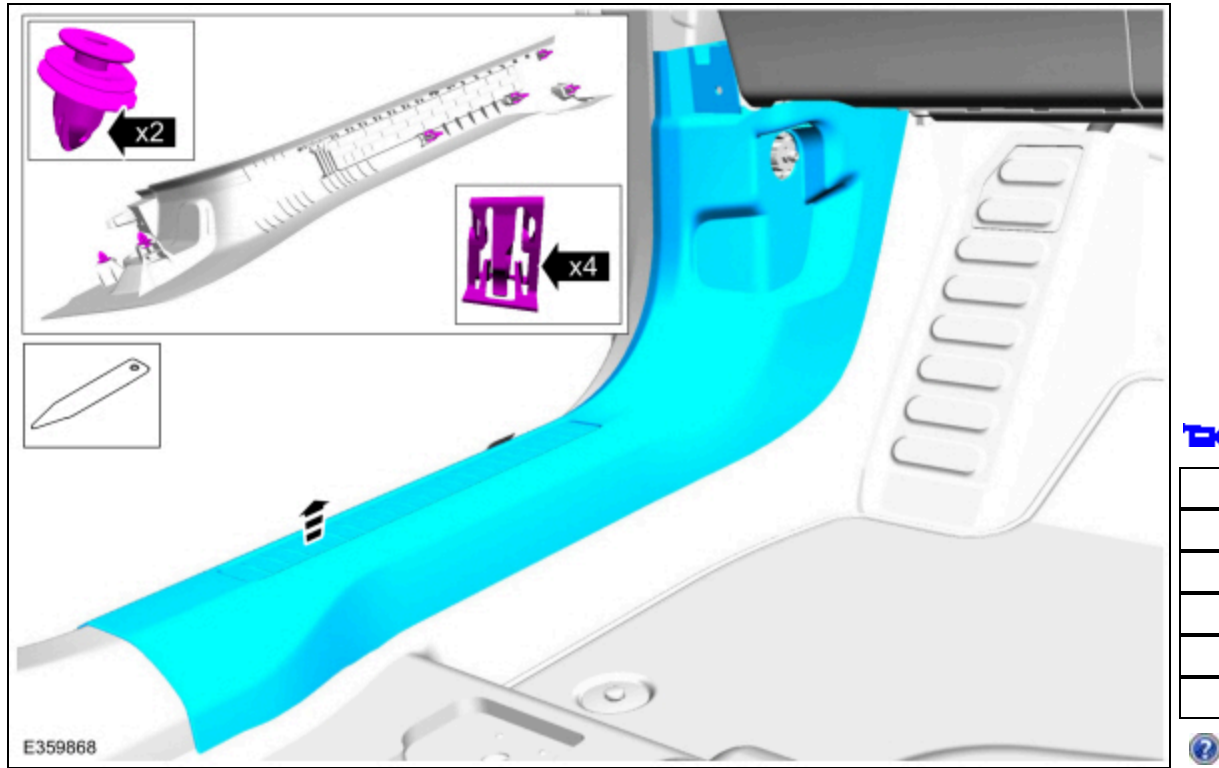

- 19. Remove the cover, the nut and foot rest pad.
Use the General Equipment: Interior Trim Remover
Torque: 48 lb.in (5.4 Nm)

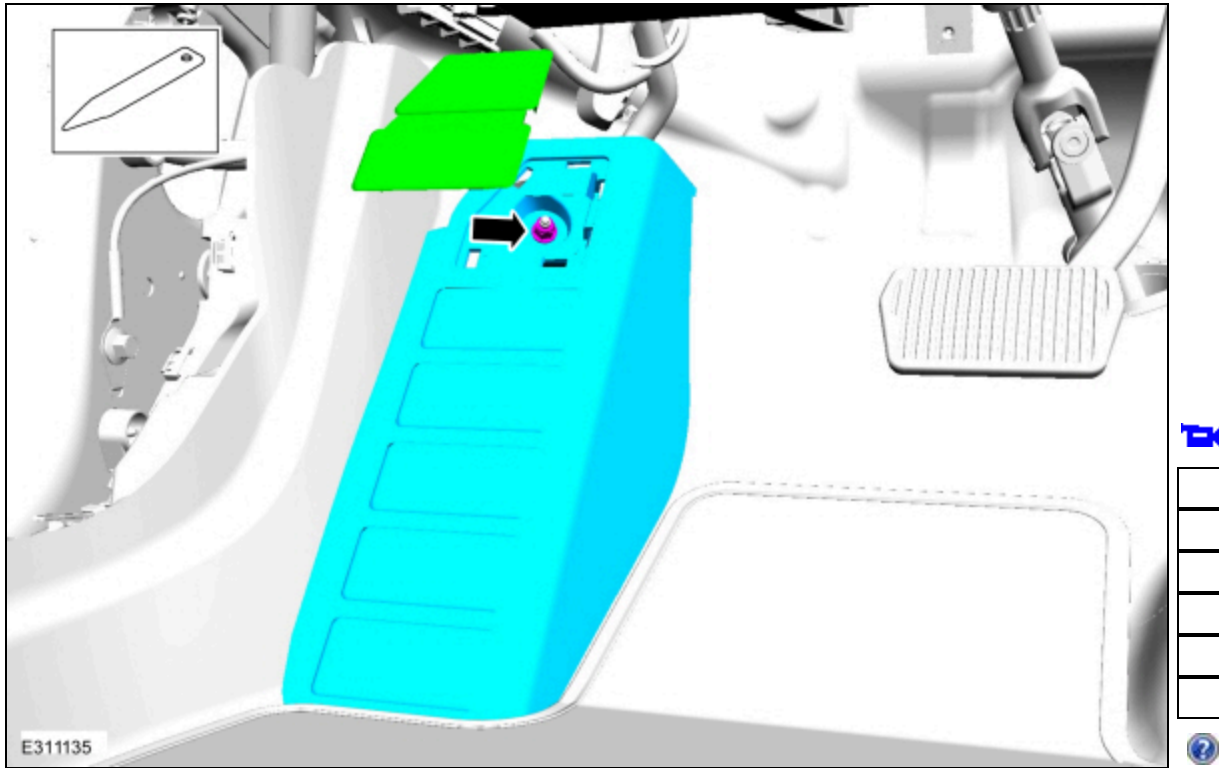

20. Remove the retainers and position the carpet aside.

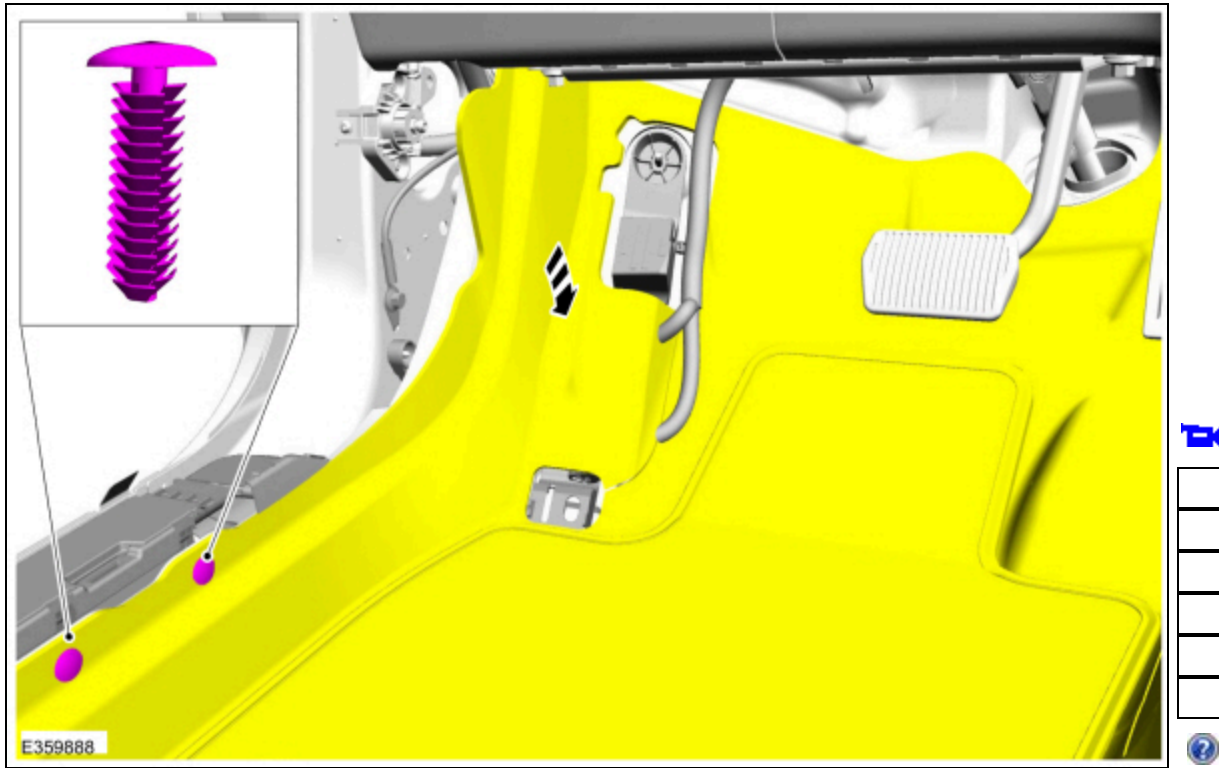

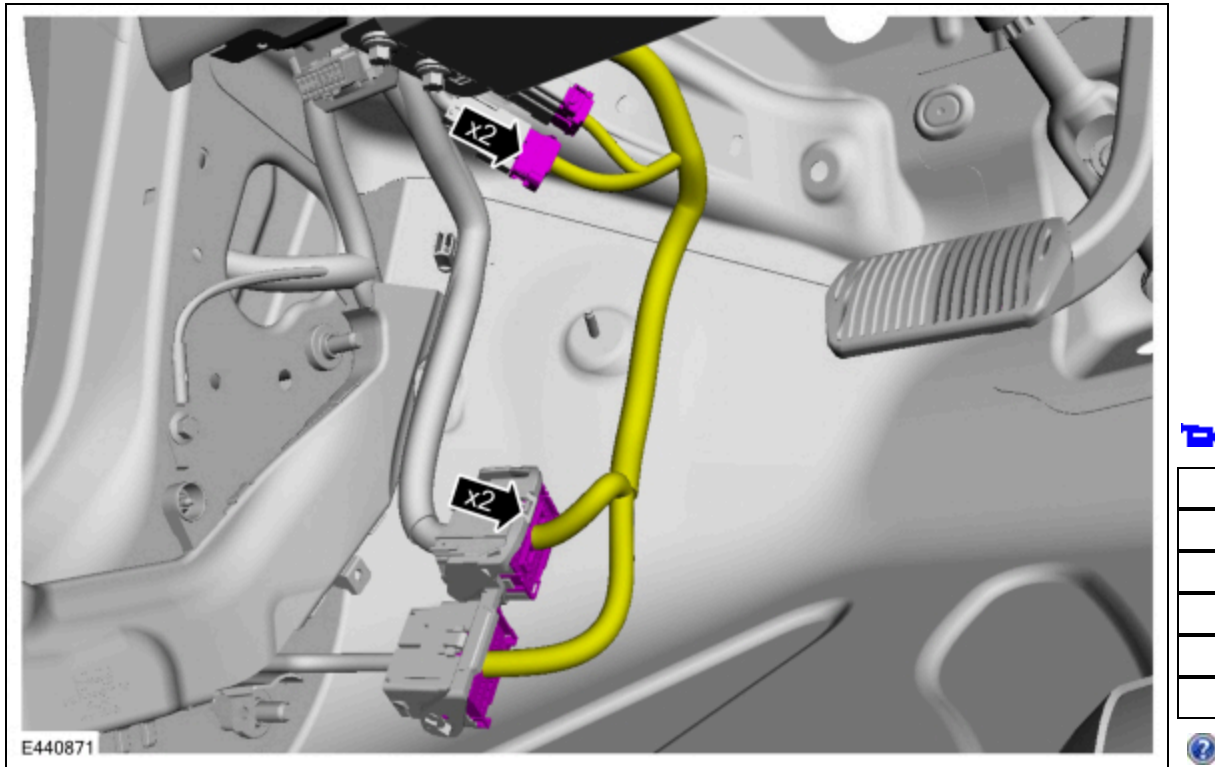

21. Disconnect the electrical connectors.

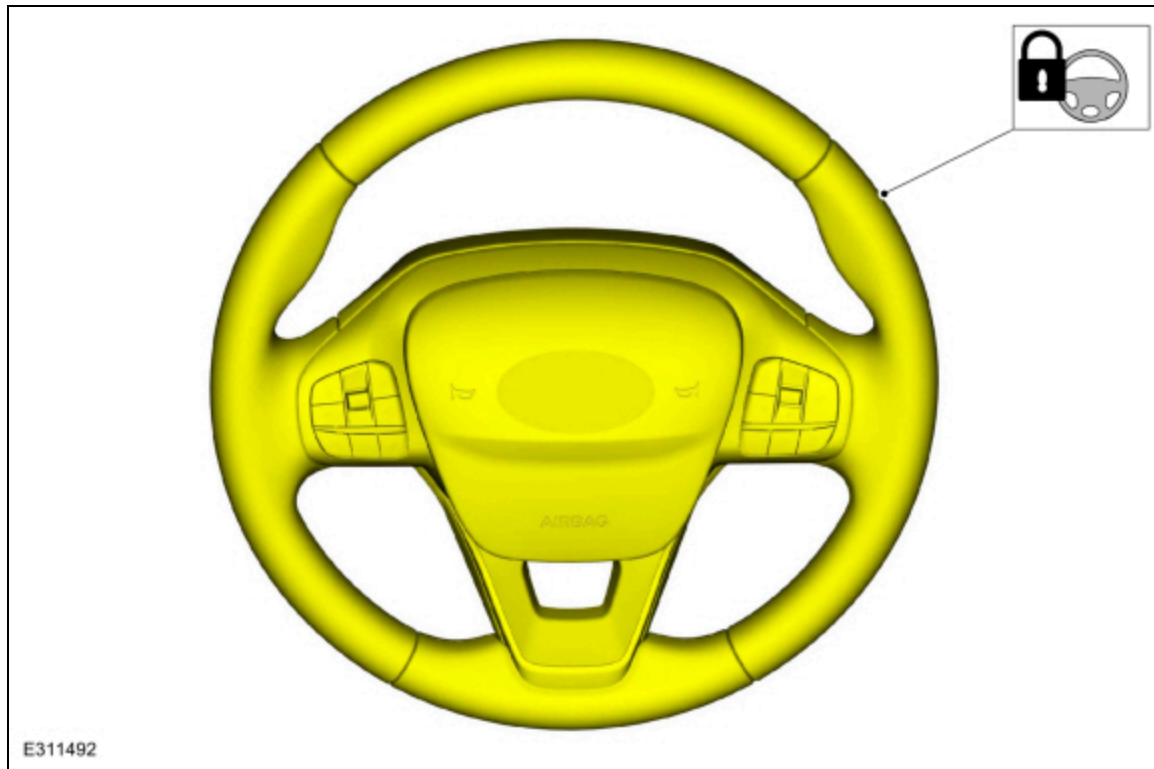

22. **NOTICE:** Do not allow the steering wheel to rotate while the steering column shaft is disconnected or damage to the clockspring may result. If there is evidence that the shaft has rotated, remove and recenter the clockspring

Secure the steering wheel.



23.  **WARNING: Do not reuse steering column shaft bolts. This may result in fastener failure and steering column shaft detachment or loss of steering control. Failure to follow this instruction may result in serious injury to vehicle occupant(s).**

1. Remove and discard the steering shaft coupler retainer.

Torque:

Stage 1: 35 lb.ft (48 Nm)

Stage 2: 120°

2. Separate the steering column shaft from the steering column.

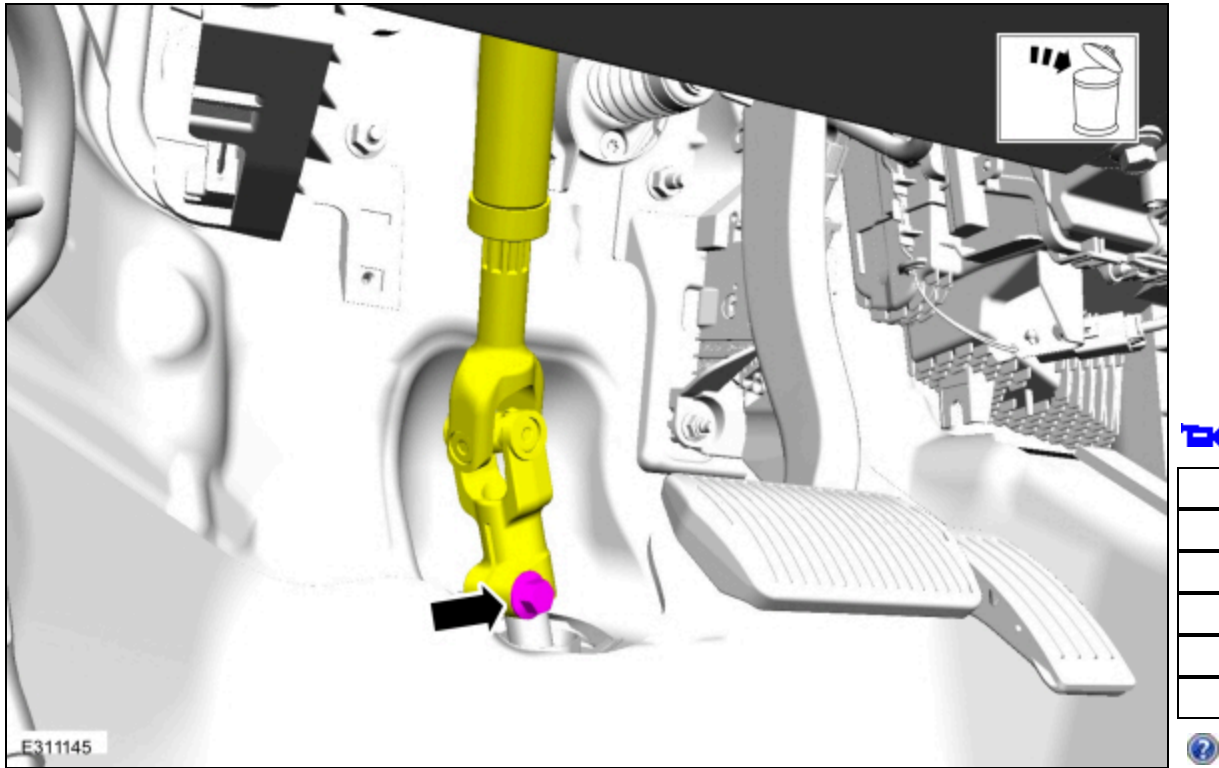

24. Disconnect the electrical connectors, release the harness retainers and position the harness aside.

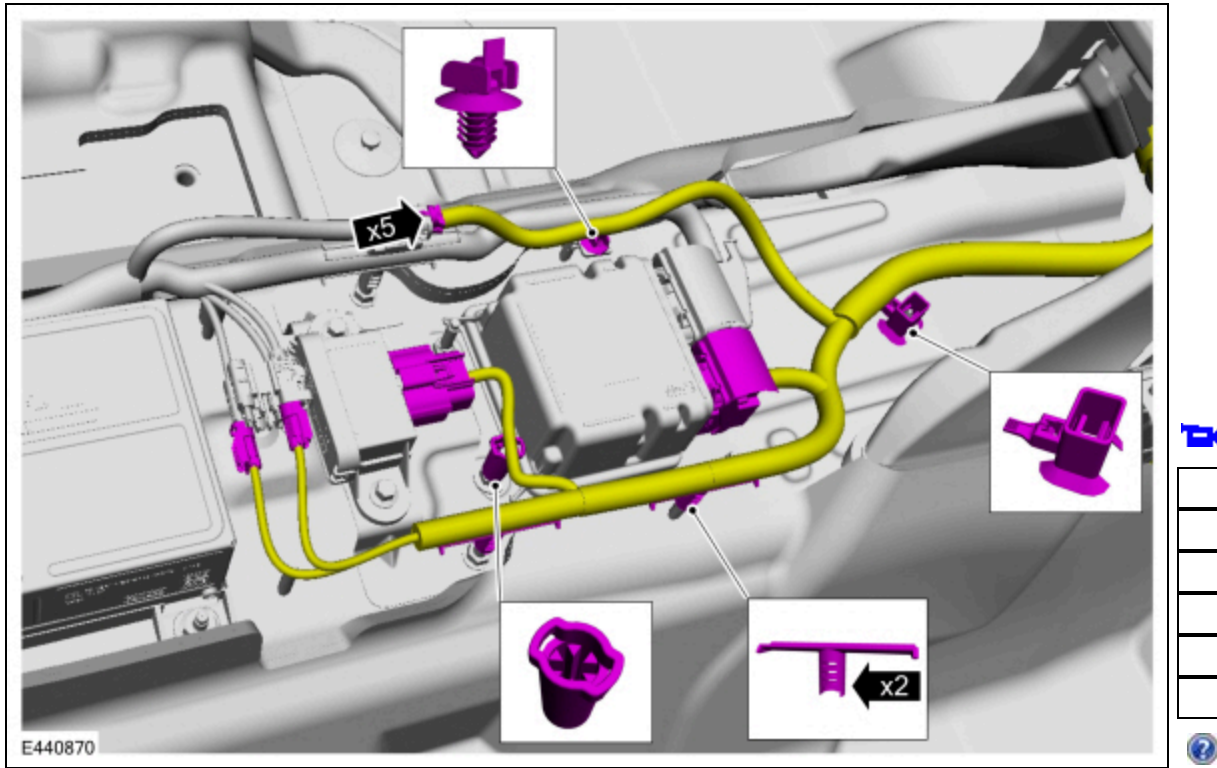

- 25.
 1. Release the clips and remove the cover.
 2. Remove the retainers.
 3. Position the carpet aside.

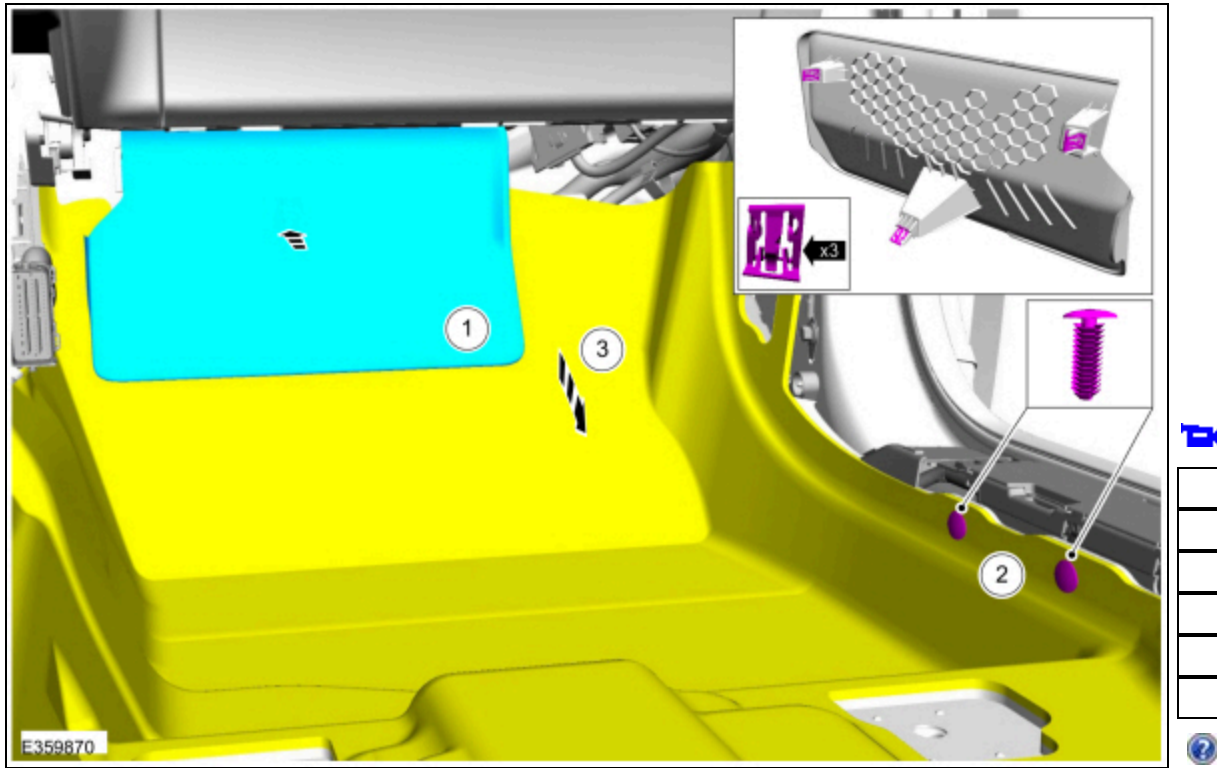

26. Disconnect the electrical connectors.

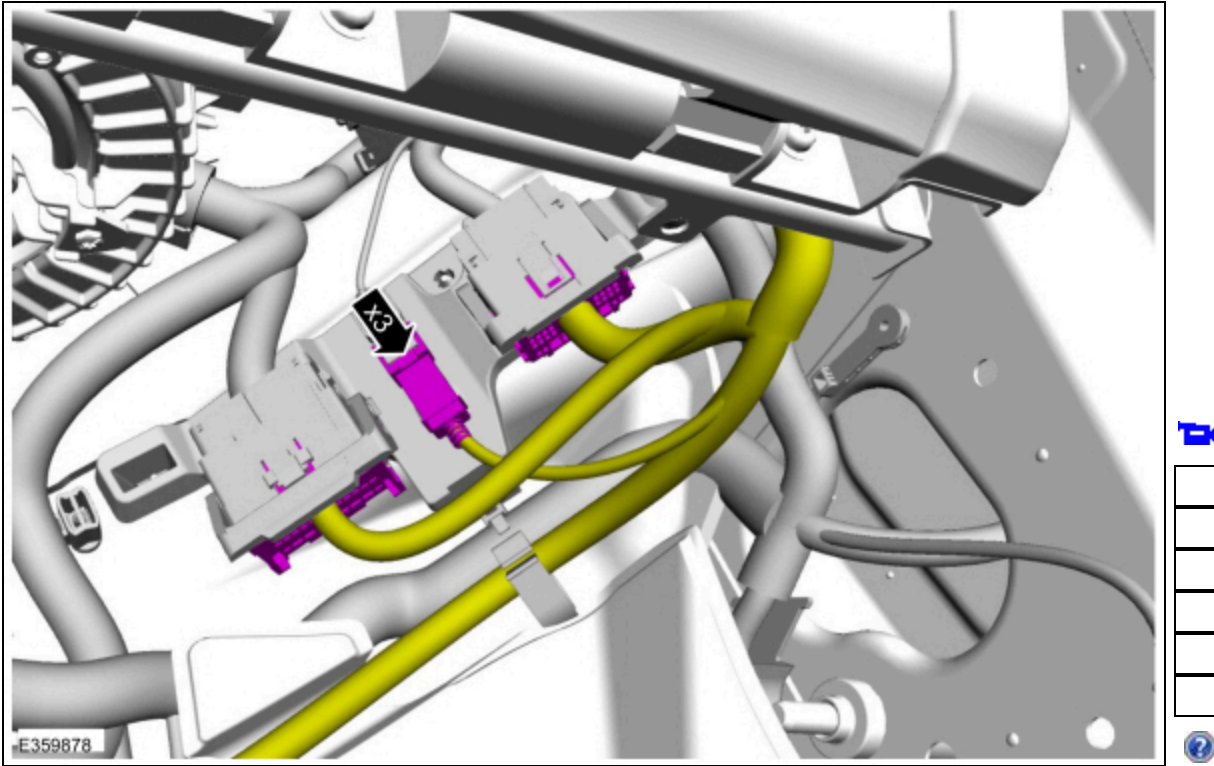

27. Disconnect the electrical connectors and release the harness retainers.

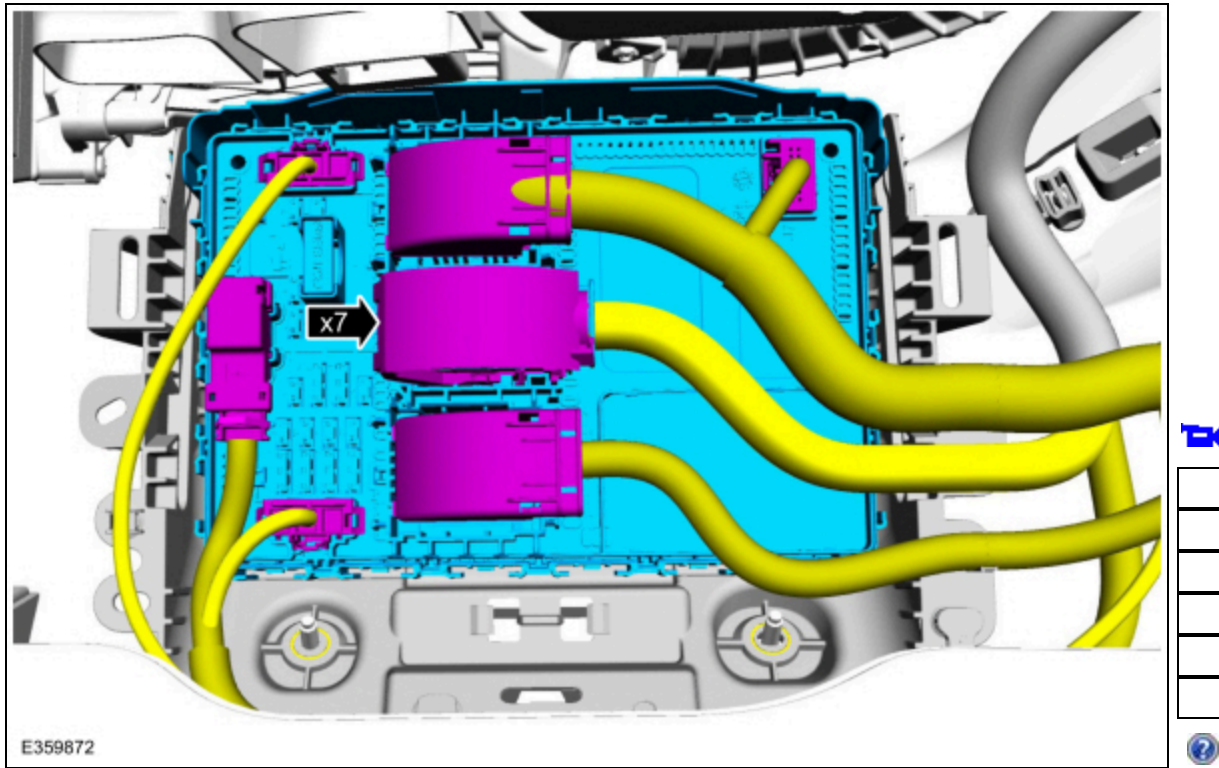

28. Release the clips and remove the BCM .

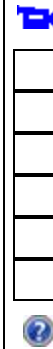
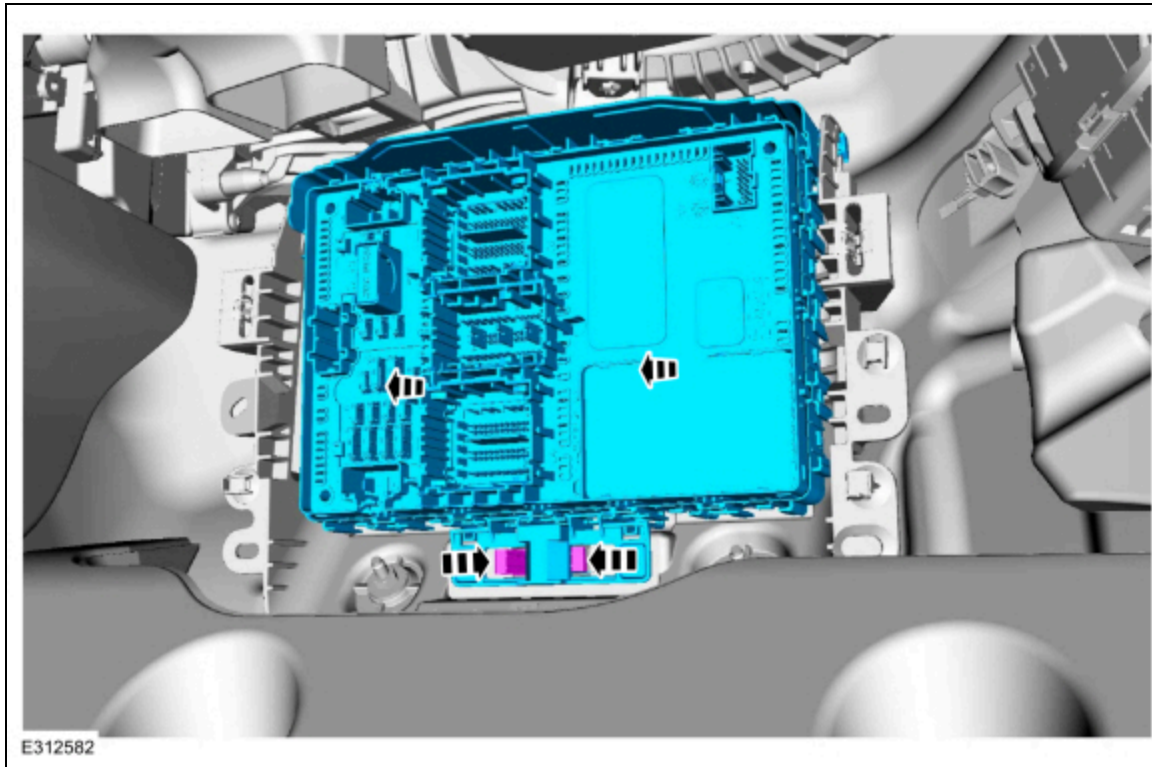

29. Remove the nut.
Torque: 62 lb.in (7 Nm)

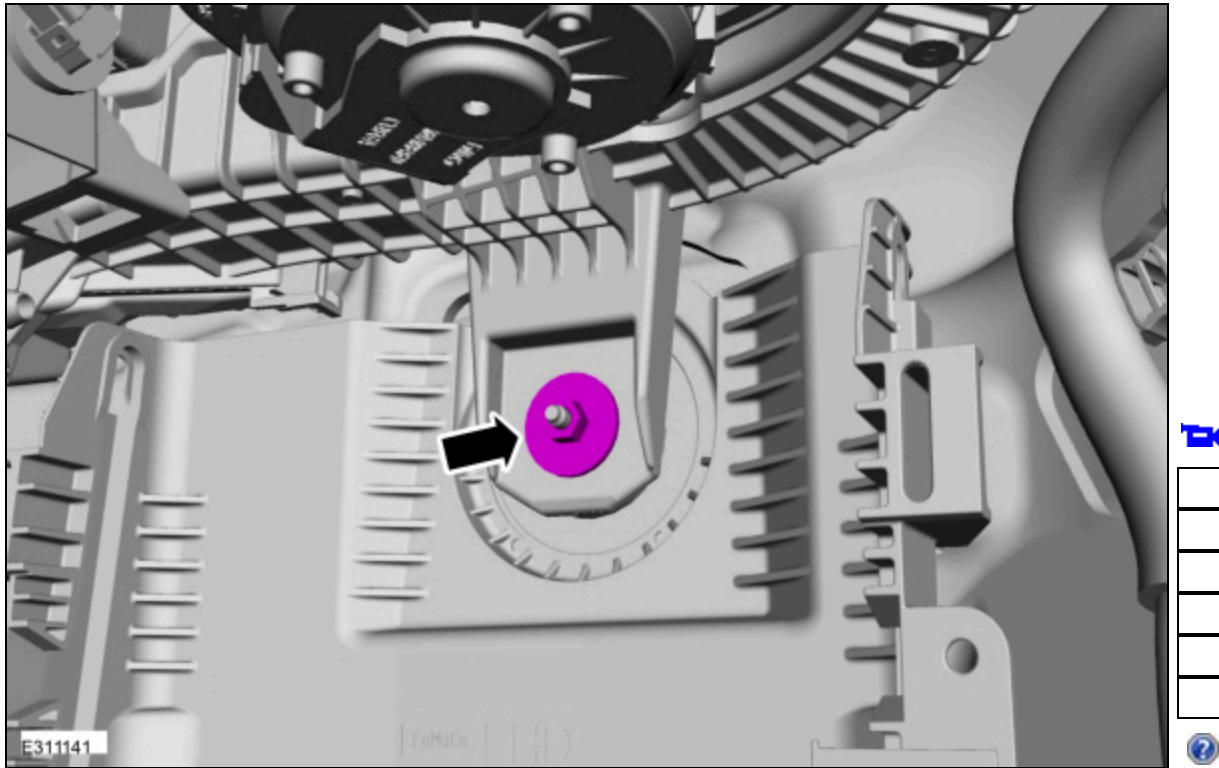

30. Remove the nuts and the bracket.
Torque: 18 lb.ft (25 Nm)

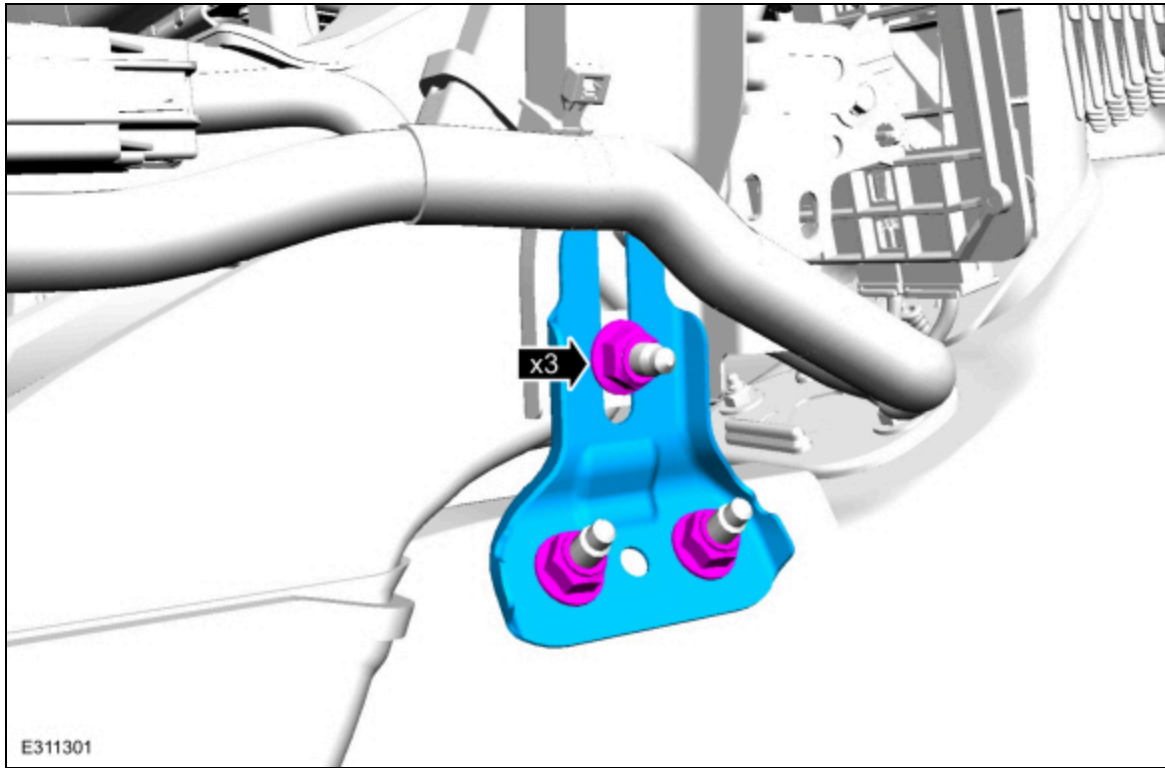

31. Remove the nuts and the bracket.
Torque: 18 lb.ft (25 Nm)

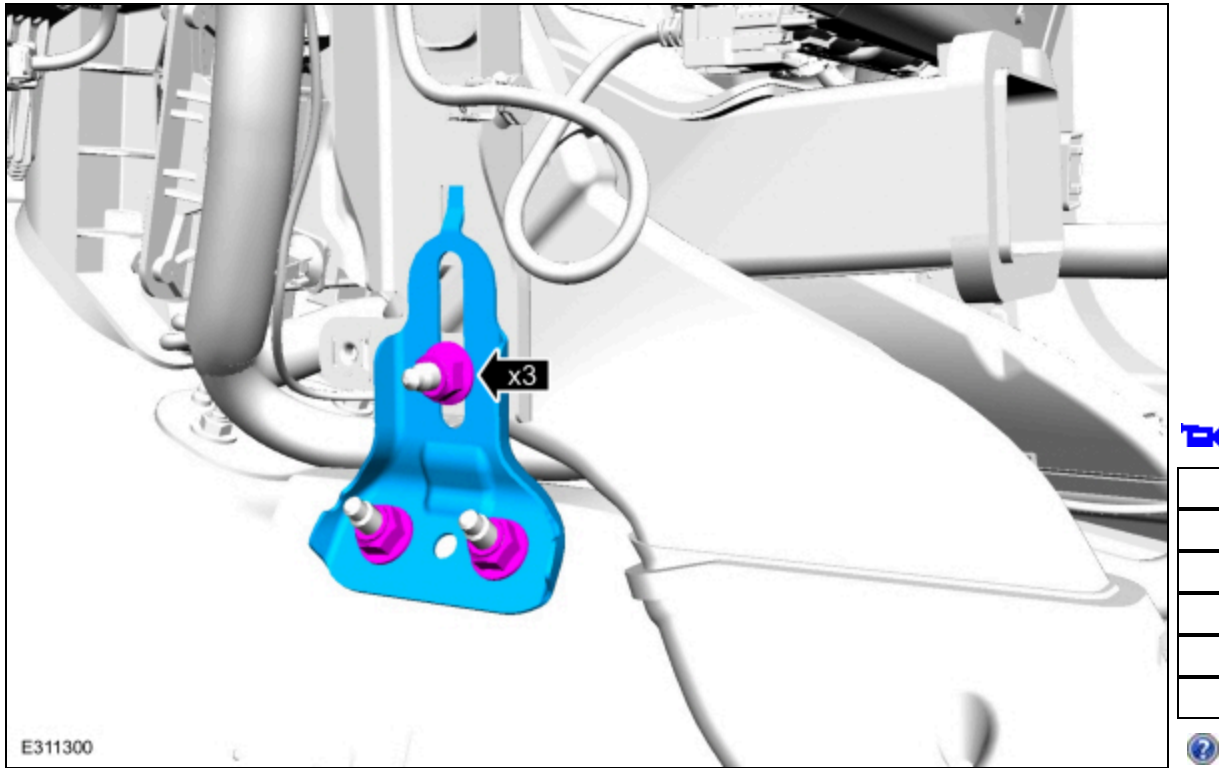

32. Remove the HVAC ducts.

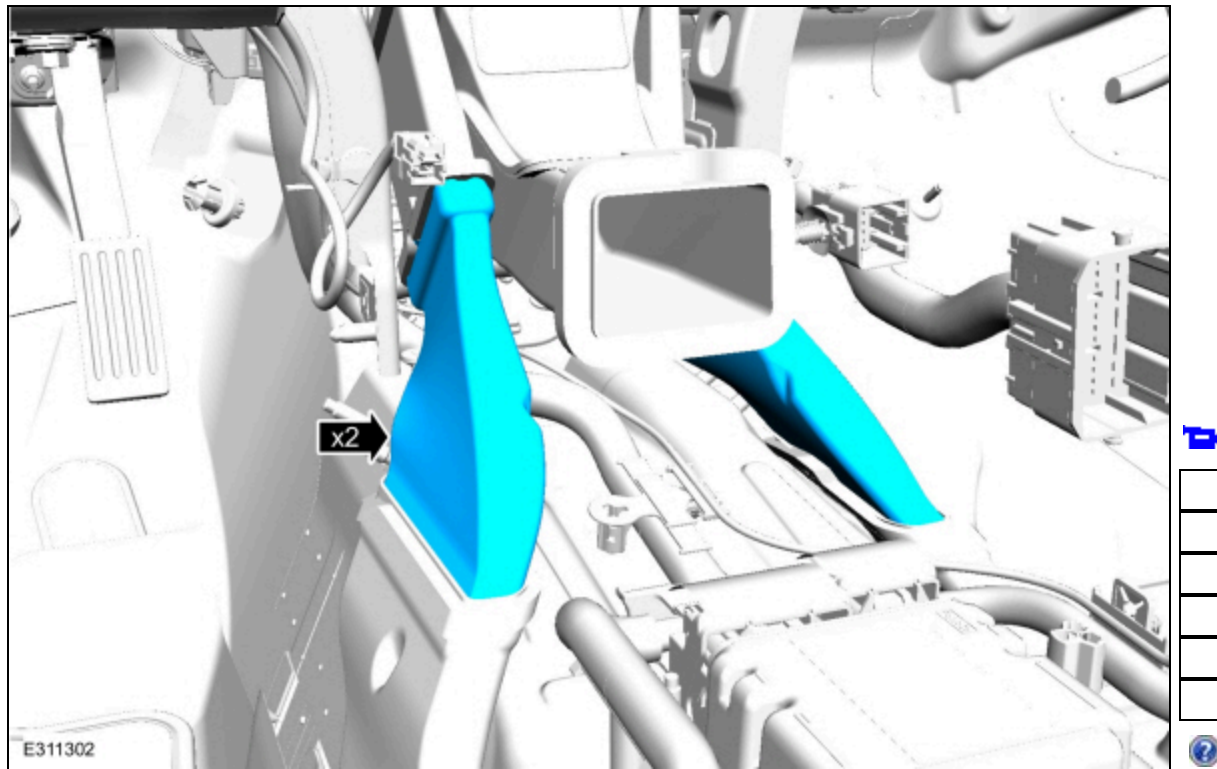

33. **NOTE:** Leave the top bolt finger tight until ready to remove the instrument panel.

1. Remove the cover, and the bolt.
Torque: 18 lb.ft (25 Nm)
2. Remove the bolts.
Torque: 35 lb.ft (47.5 Nm)

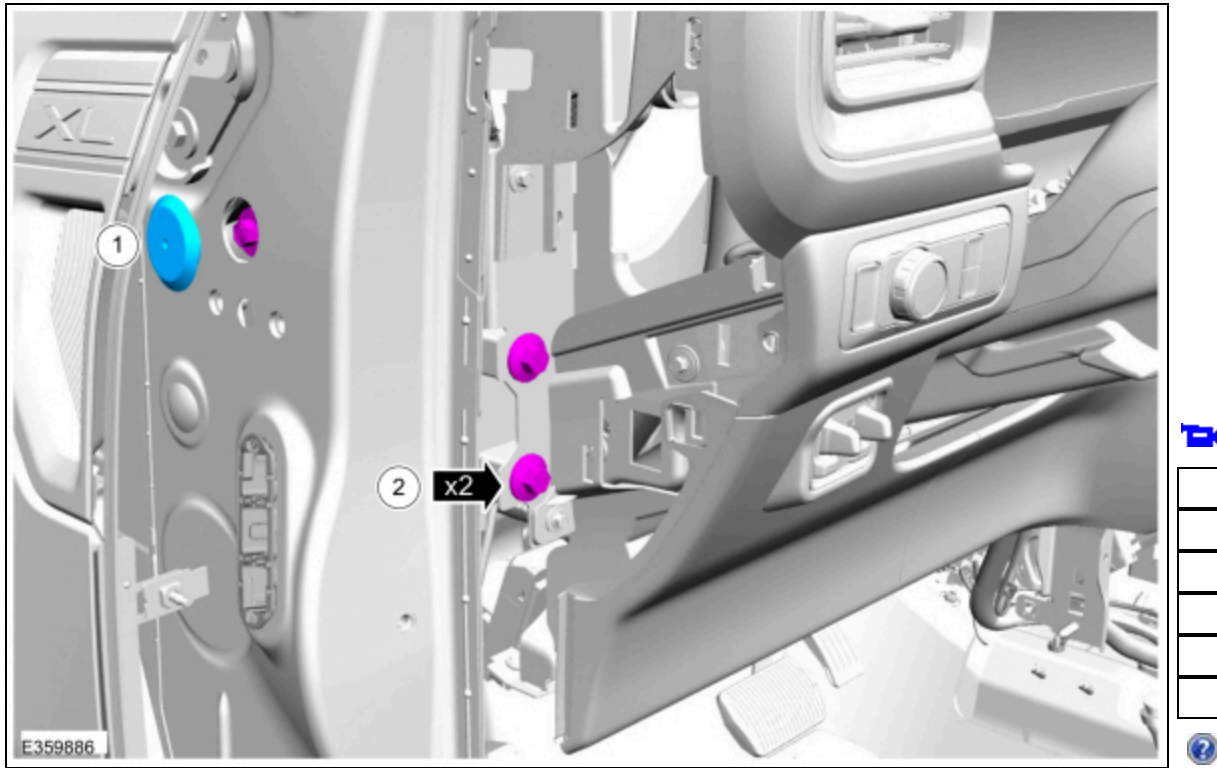

34. **NOTE:** Leave the top bolt finger tight until ready to remove the instrument panel.

Remove the bolts.

Torque: 35 lb.ft (47.5 Nm)

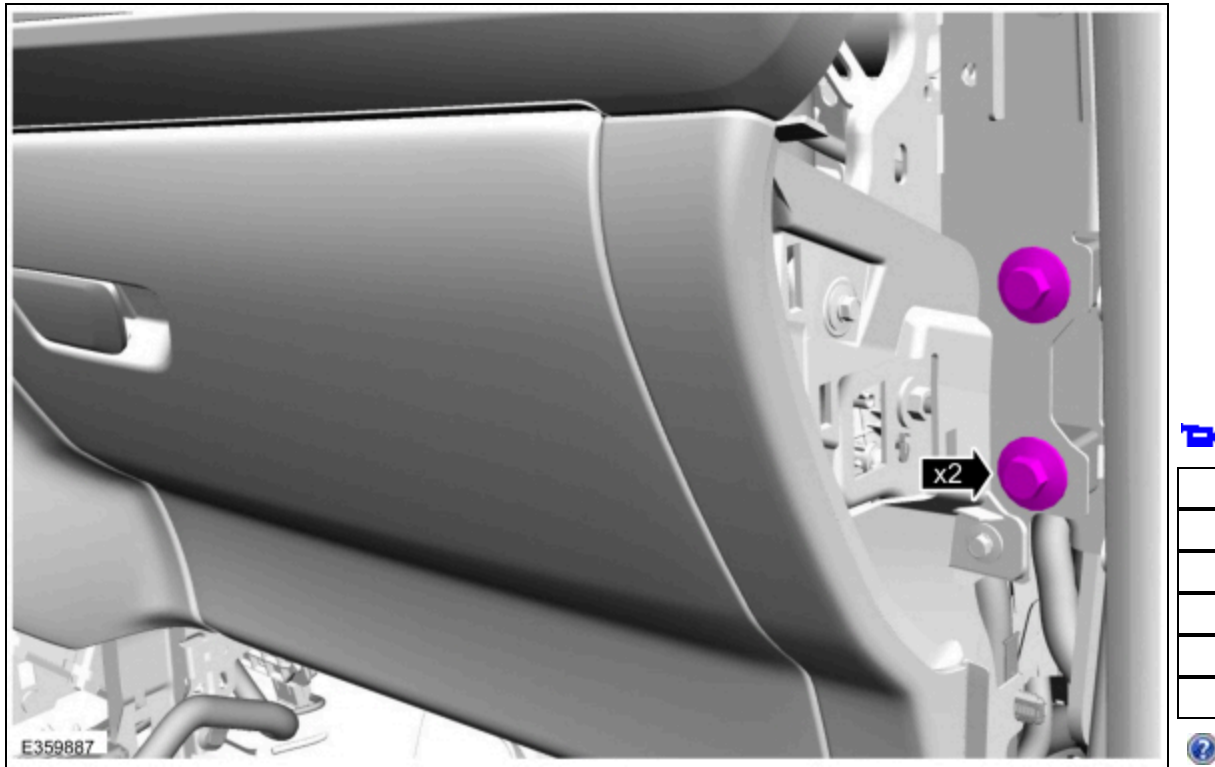

35. **NOTE:** To avoid damaging the instrument panel, an assistant is required when carrying out this step.

NOTE: Make sure not to damage the instrument panel when removing the instrument panel from the vehicle.

NOTE: Make sure that all electrical connectors and wiring are not hindered before removing the instrument panel or damage to the components may occur.

Remove the instrument panel through the passenger door opening.

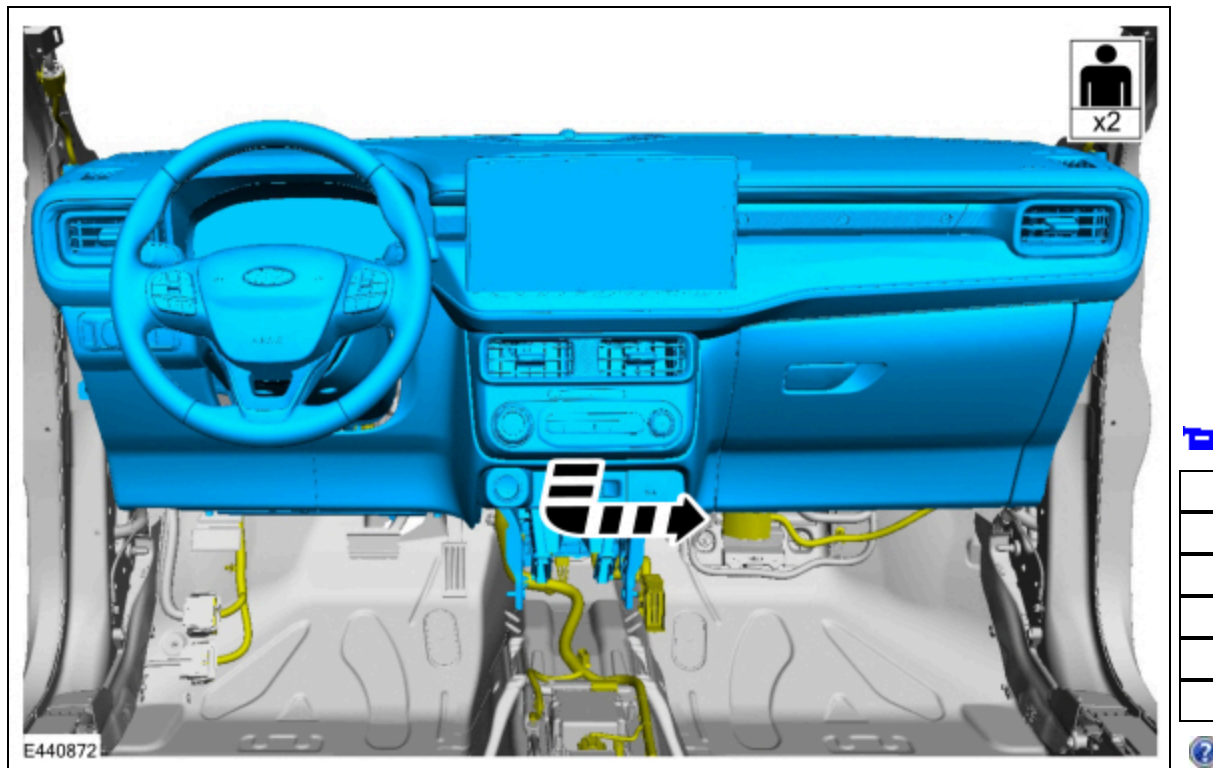

Installation

1. To install, reverse the removal procedure.
2. Fill and bleed the cooling system.
Refer to: [Cooling System Filling and Bleeding \(303-03C Electric Powertrain Cooling, General Procedures\)](#).
Refer to: [Engine Cooling System Draining, Vacuum Filling and Bleeding \(303-03B Engine Cooling - 2.5L Duratec – Hybrid \(121kW/164PS\) \(S3\), General Procedures\)](#).
Refer to: [Engine Cooling System Draining, Vacuum Filling and Bleeding \(303-03A Engine Cooling - 2.0L EcoBoost \(184kW/250PS\) \(E3\), General Procedures\)](#).

© Copyright 2025, Ford Motor Company.

